



PRODUCT **SORA 600 VANITY CARCASS**

UNIT SIZE **600w x 540d x 820h**

BASIN OPT1 **LAMBRO 600w x 460d x 60h**

BASIN OPT2 **PRESPA 605w x 480d x 15h**

FITTING ADVICE

- The shaded areas indicate the clear voids for the running of services.
- This unit can tilt forward. A secure wall fixing is required.
- To aid installation, it is recommended to remove the doors to give full access and to avoid damage.
- All wall to carcass and wall to basin joints should be sealed with silicone
- All dimensions are in mm.

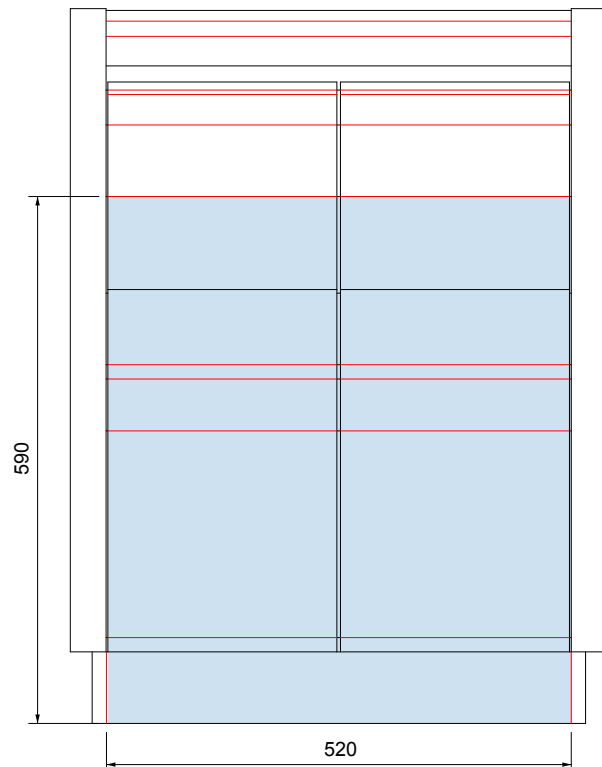
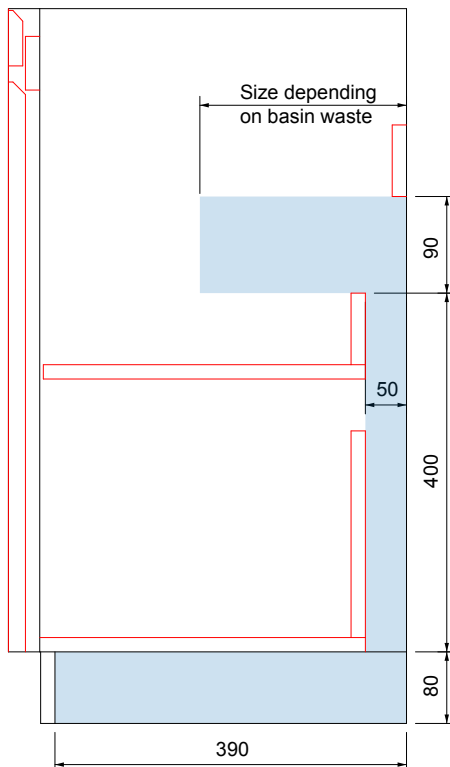

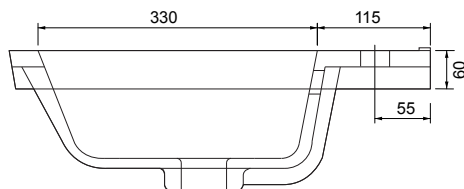
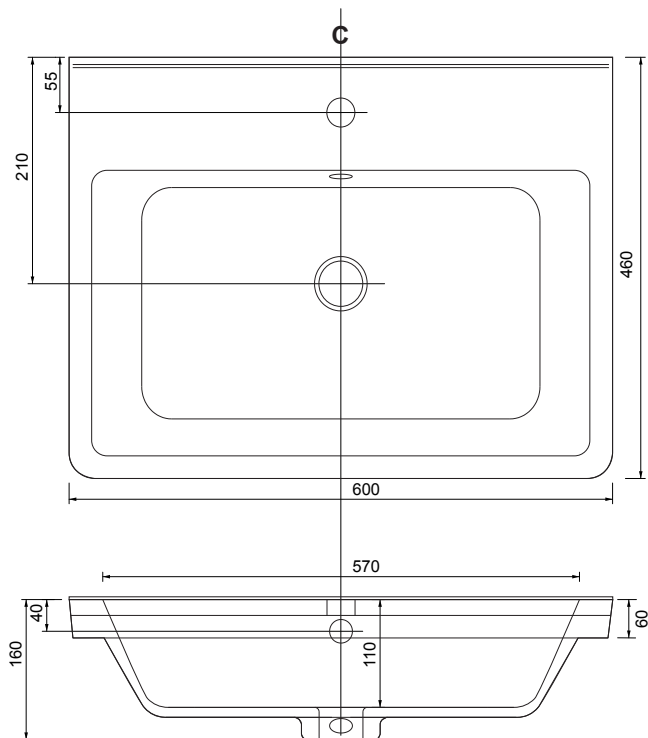

CERAMIC BASINS

Ceramic Basins are made out of liquefied fireclay which is poured into a mould and allowed to set before being hand finished. A ground glass glaze would typically be sprayed over the basin before the final firing.

This long-lasting, durable material suits a simple and minimalistic bathroom suite as well as a traditional Victorian look. Stains are easily removed and ceramic is generally easy to clean to maintain a shiny appearance. The slight ripples occasionally seen along its surface are often mistaken for flaws these are actually part of the ceramic basins characteristics.



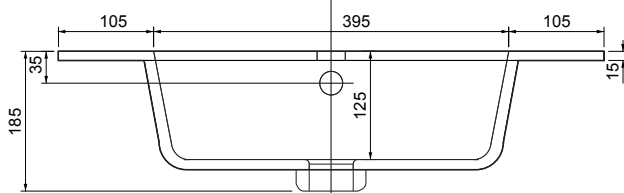
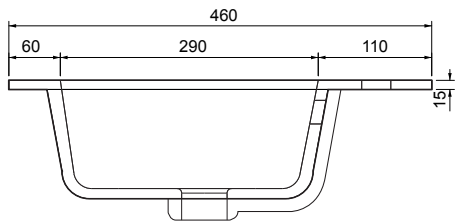
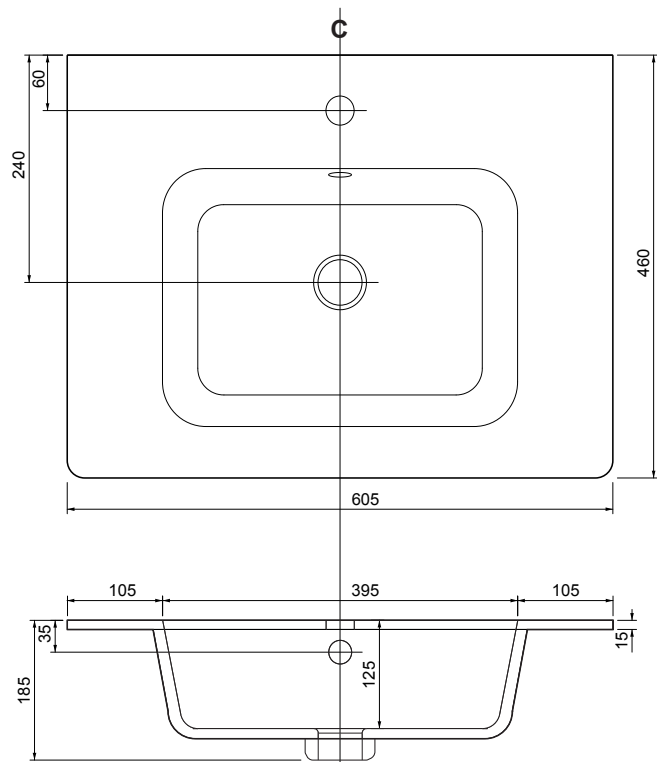

CERAMIC BASINS

Ceramic Basins are made out of liquefied fireclay which is poured into a mould and allowed to set before being hand finished. A ground glass glaze would typically be sprayed over the basin before the final firing.

This long-lasting, durable material suits a simple and minimalistic bathroom suite as well as a traditional Victorian look. Stains are easily removed and ceramic is generally easy to clean to maintain a shiny appearance. The slight ripples occasionally seen along its surface are often mistaken for flaws these are actually part of the ceramic basins characteristics.



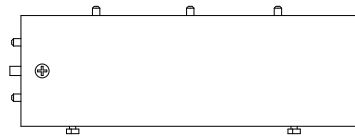

2x Side Rail

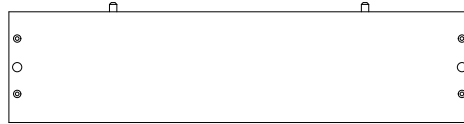

1x Front Plinth

FIXING TOGETHER

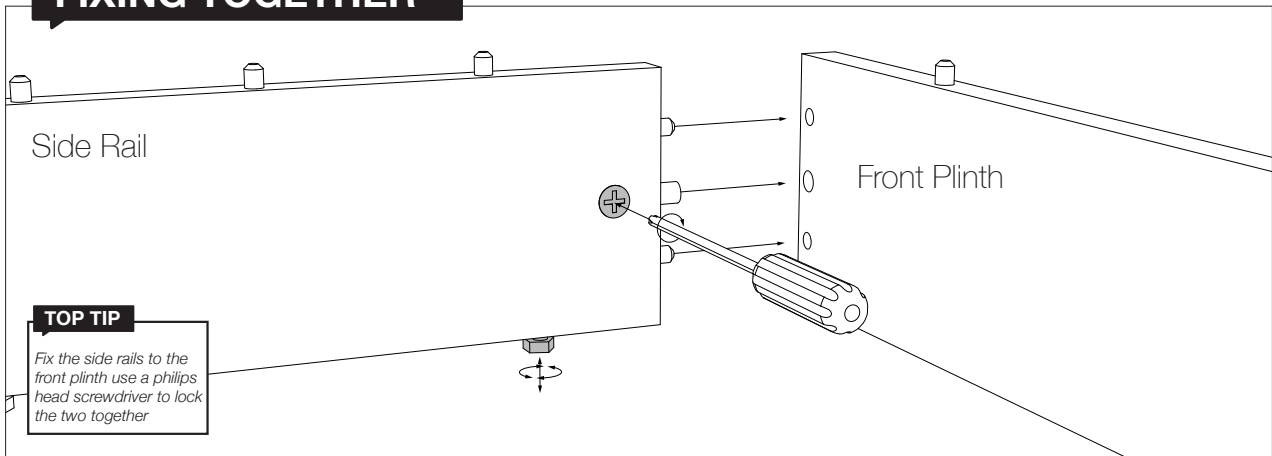

ATTACHING TO THE UNIT

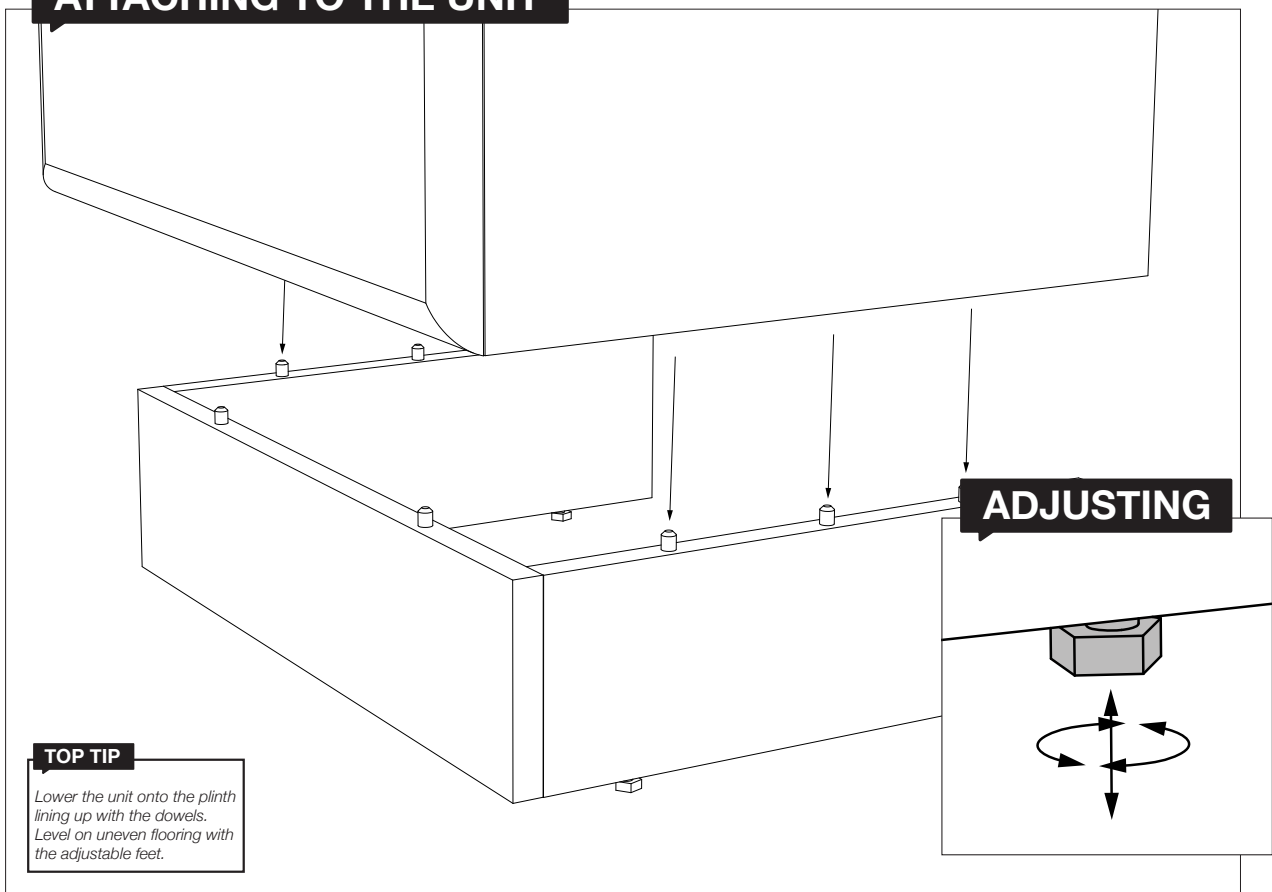

To aid installation, it is recommended to remove the doors and shelf to give full access and to avoid damage.

1. Fix through the pre installed wall bracket.
2. Silicone around the top of the unit and place basin.
3. Silicone around the rear of the unit at wall abutment.
4. Re-fit doors and shelf

